

MEY

Ultra Drill Mill

Multi-Function Endmill

- ◆ 2 flute effective design for milling
- ◆ Improved stability and tool life
- ◆ Low cutting resistance
- ◆ Good chip evacuation when drilling and slant milling



Multi-Function Machining

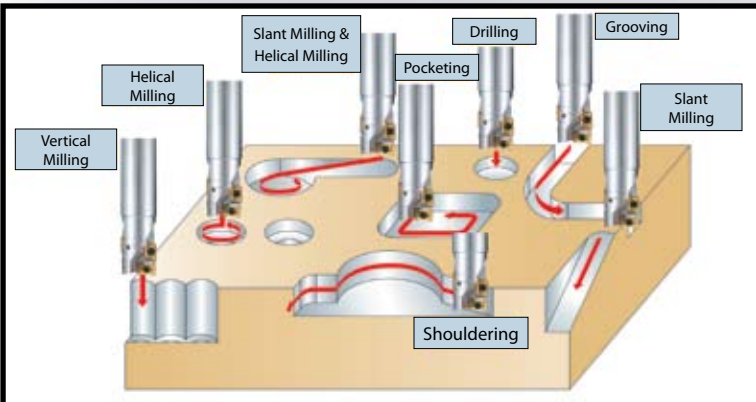

Cutting Resistance Comparison

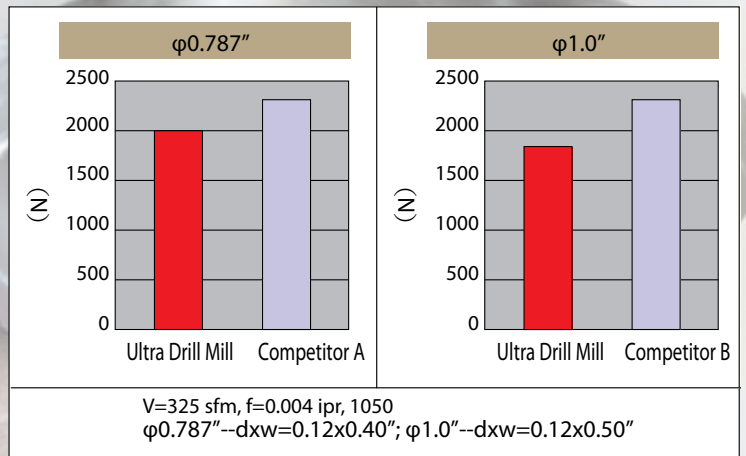

PVD Coated Carbide Grades
 PR830 for Steel and Stainless
 PR905 for Cast Iron

JOMT GOMT



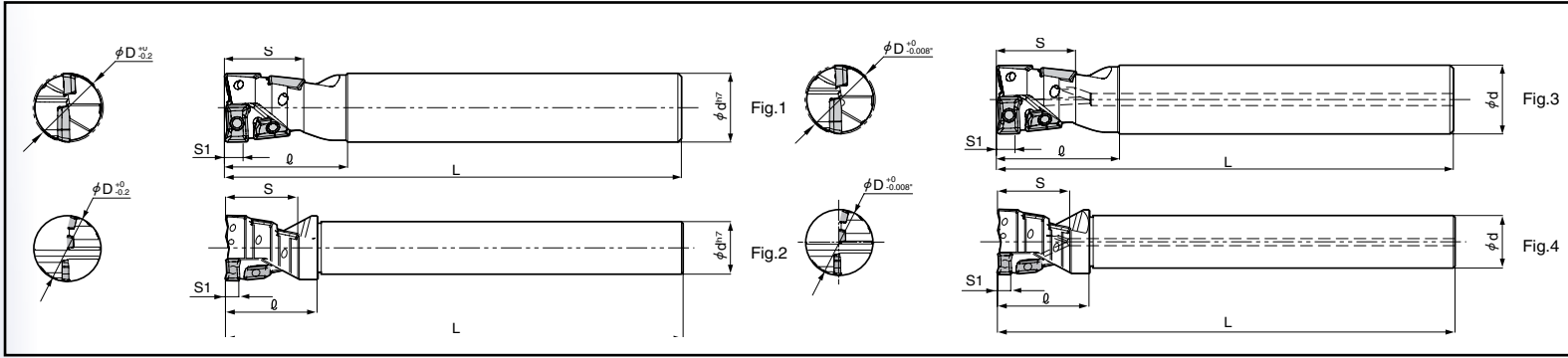

MEY Ultra Drill Mill

Description	Stock	No. of Inserts	No. of Flutes	Unit	Dimension						Rake Angle (°)		Drawing	Spare Parts				
					ΦD	Φd	L	ℓ	S	S1	A.R.	R.R.		Inserts Screw	Wrench	Anti-seize Compound		
Standard (Straight)	MEY 16-S16	○	4	2	mm	16	16	120	31	19	4.5	+11°	-11°	Fig.1	SB-2040TRG	FT-6	MP-1	
	17-S16	○	4	2	mm	17	16	120	31	19	4.5	+11°	-11°		SB-2040TRG	FT-6		
	20-S20	○	4	2	mm	20	20	130	35	22	6	+13°	-9°		SB-255TRG	DT-8		
	21-S20	○	4	2	mm	21	20	130	35	22	6	+13°	-9°		SB-255TRG	DT-8		
	25-S25	○	4	2	mm	25	25	140	40	28	7.5	+13°	-11°		SB-3070TRG	DT-10		
	26-S25	○	4	2	mm	26	25	140	40	28	7.5	+13°	-11°		SB-3070TRG	DT-10		
	32-S32	○	4	2	mm	32	32	150	50	36	9.5	+13°	-9°		SB-4070TRG	DT-15		
	33-S32	○	4	2	mm	33	32	150	50	36	9.5	+13°	-9°		SB-4070TRG	DT-15		
	40-S32	○	7	2	mm	40	32	160	55	42	7.5	+13°	-11°	Fig.2	SB-3070TRG	DT-10		
50-S42	○	7	2	mm	50	42	170	70	54	9.5	+13°	-9°	SB-4070TRG	DT-15				
Long Head (Straight)	MEY 16-S16-140H	○	4	2	mm	16	16	140	51	19	4.5	+11°	-11°	Fig.1	SB-2040TRG	FT-6	MP-1	
	20-S20-150H	○	4	2	mm	20	20	150	53	22	6	+13°	-9°		SB-255TRG	DT-8		
	25-S25-170H	○	4	2	mm	25	25	180	70	28	7.5	+13°	-11°		SB-3070TRG	DT-10		
	32-S32-180H	○	4	2	mm	32	32	180	80	36	9.5	+13°	-9°		SB-4070TRG	DT-15		
Long Shank (Straight)	MEY 16-S16-190	○	4	2	mm	16	16	190	61	19	4.5	+11°	-11°	Fig.1	SB-2040TRG	FT-6	MP-1	
	17-S16-190	○	4	2	mm	17	16	190	31	19	4.5	+11°	-11°		SB-2040TRG	FT-6		
	20-S20-200	○	4	2	mm	20	20	200	63	22	6	+13°	-9°		SB-2555TRG	DT-8		
	21-S20-200	○	4	2	mm	21	20	200	35	22	6	+13°	-9°		SB-255TRG	DT-8		
	25-S25-220	○	4	2	mm	25	25	220	80	28	7.5	+13°	-11°		SB-3070TRG	DT-10		
	26-S25-220	○	4	2	mm	26	25	220	40	28	7.5	+13°	-11°		SB-3070TRG	DT-10		
	32-S32-230	○	4	2	mm	32	32	230	90	36	9.5	+13°	-9°		SB-4070TRG	DT-15		
	33-S32-230	○	4	2	mm	33	32	230	50	36	9.5	+13°	-9°		SB-4070TRG	DT-15		
	40-S32-240	○	7	2	mm	40	32	240	55	42	7.5	+13°	-11°	Fig.2	SB-3070TRG	DT-10		
50-S42-250	○	7	2	mm	50	42	250	70	54	9.5	+13°	-9°	SB-4070TRG	DT-15				
Standard (With Coolant Hole)	MEY 625-S625-HG	●	4	2	inch	0.630	0.625	4.699	1.195	0.748	0.177	+11°	-11°	Fig.3	SB-2040TRG	FT-6	MP-1	
	750-S750-HG	●	4	2	inch	0.787	0.750	5.091	1.350	0.866	0.236	+13°	-9°		SB-2555TRG	DT-8		
	1000-S100-HG	●	4	2	inch	1.000	1.000	5.486	1.549	1.102	0.295	+13°	-11°		SB-3070TRG	DT-10		
	1250-S125-HG	●	4	2	inch	1.250	1.250	5.858	1.921	1.417	0.374	+13°	-9°		SB-4070TRG	DT-15		
	1500-S125-HG	●	7	2	inch	1.500	1.250	6.260	2.126	1.654	0.295	+13°	-11°		Fig.4	SB-3070TRG		DT-10
	2000-S150-HG	●	7	2	inch	1.984	1.500	6.649	2.712	2.126	0.374	+13°	-9°		SB-4070TRG	DT-15		

● : Standard Stock
○ : World Express

MEY Applicable Inserts

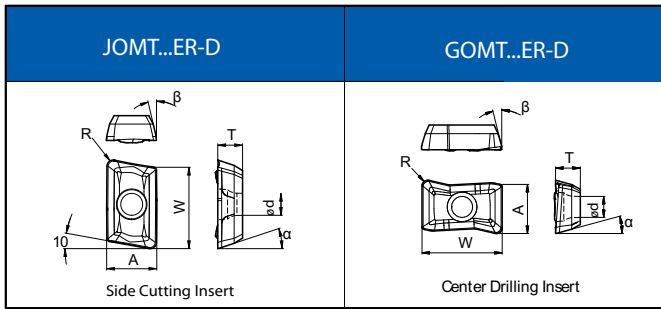

Description	Dimension (inch)					Angle (°)		Stock Grades	
	A	T	Φd	W	R	α	β	PVD Coated	
								PR830	PR905
JOMT 08T208ER-D 100308ER-D 13T308ER-D 16-4-8ER-D	0.200 0.250 0.320	0.110 0.130 0.150	0.090 0.110 0.130	0.330 0.400 0.520	0.03	17°	13°	● ● ●	● ● ●
GOMT 08T208ER-D 100308ER-D 13T308ER-D 160408ER-D	0.210 0.260 0.330 0.390	0.110 0.130 0.150 0.190	0.090 0.110 0.130 0.170	0.340 0.420 0.520 0.660	0.03	18°	13°	● ● ● ●	● ● ● ●

● : Standard Stock

Endmill	Insert			
	Side Edge	Qty	Center Edge	Qty
MEY 16-S16(-...)	JOMT 08T208ER-D	3	GOMT 08T208ER-D	1
17-S16(-...)	JOMT 08T208ER-D	3	GOMT 08T208ER-D	1
20-S20(-...)	JOMT 100308ER-D	3	GOMT 100308ER-D	1
21-S20(-...)	JOMT 100308ER-D	3	GOMT 100308ER-D	1
25-S25(-...)	JOMT 13T308ER-D	3	GOMT 13T308ER-D	1
26-S25(-...)	JOMT 13T308ER-D	3	GOMT 13T308ER-D	1
32-S32(-...)	JOMT 160408ER-D	3	GOMT 160408ER-D	1
33-S32(-...)	JOMT 160408ER-D	3	GOMT 160408ER-D	1
40-S32(-...)	JOMT 13T308ER-D	6	GOMT 13T308ER-D	1
50-S42(-...)	JOMT 160408ER-D	6	GOMT 160408ER-D	1
625-S625-HG	JOMT 08T208ER-D	3	GOMT 08T208ER-D	1
750-S750-HG	JOMT 100308ER-D	3	GOMT 100308ER-D	1
1000-S100-HG	JOMT 13T308ER-D	3	GOMT 13T308ER-D	1
1250-S125-HG	JOMT 160408ER-D	3	GOMT 160408ER-D	1
1500-S125-HG	JOMT 13T308ER-D	6	GOMT 13T308ER-D	1
2000-S150-HG	JOMT 160408ER-D	6	GOMT 160408ER-D	1

Recommended Cutting Conditions

Work Material	Feed Rate (ipt)		Insert Grade (Speed)	
	Drilling	Shouldering - Grooving	PVD Coated	
			PR830	PR905
Stainless Steel	0.003~0.005	0.002~0.006	325~600	-
Carbon Steel	0.003~0.006	0.002~0.010	400~650	-
Alloy Steel	0.003~0.006	0.002~0.010	325~600	-
Metal Mold Steel	0.003~0.006	0.002~0.006	250~500	-
Cast Iron	0.002~0.008	0.002~0.010	-	325~650

Drilled Hole Bottom Shape

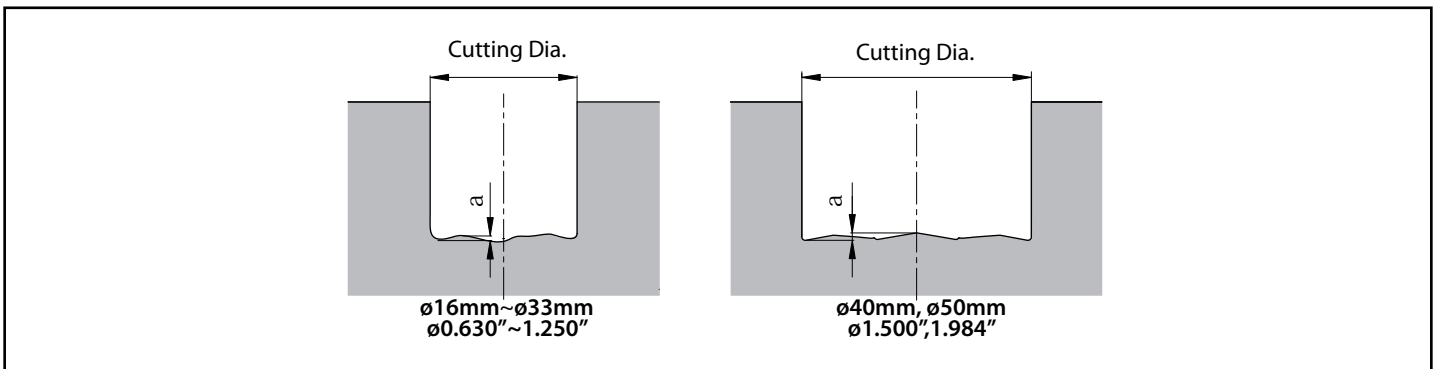

Cutting Diameter	Φ16mm, Φ17mm Φ0.630"	Φ20mm, Φ21mm Φ0.787"	Φ25mm, Φ26mm Φ1.000"	Φ32mm, Φ33mm Φ1.250"	Φ40mm Φ1.500"	Φ50mm 1.984"
a (mm)	0.5mm	0.64mm	0.85mm	1.12mm	1.54mm	1.65mm
a (inch)	0.020"	0.025"	0.033"	0.044"	0.061"	0.065"

MEY Cutting Performance

Cutting Dia.	Description	Overhang Length (Inch)			Cutting Dia.	Description	Overhang Length (Inch)			Shape
		1.24	[~2.44]	(N.R.)			1.60	[~2.80]	(N.R.)	
0.630"	MEY625-S625-HG	1.24	[~2.44]	(N.R.)	1.000"	MEY1000-S1000	1.60	[~2.80]	(N.R.)	
16mm	MEY16-S16	1.24	[~2.44]	(N.R.)	25mm	MEY25-S25	1.60	[~2.80]	(N.R.)	
	MEY16-S16-140H	-	~2.44	[~3.64]		MEY25-S25-170H	-	2.80	[~4.00]	
	MEY16-S16-190	-	2.44	~3.64		MEY25-S25-220	-	~3.20	~4.00	
17mm	MEY17-S16	1.24	[~2.44]	(N.R.)	26mm	MEY26-S25	1.60	[~2.80]	(N.R.)	
	MEY17-S16-190	1.24	[~2.44]	(N.R.)		MEY26-S25-220	1.60	~2.80	~4.00	
0.787"	MEY750-S750	1.40	[~2.60]	(N.R.)	1.250"	MEY1250-S125	2.00	[~3.20]	(N.R.)	
20mm	MEY20-S20	1.40	[~2.60]	(N.R.)	32mm	MEY32-S32	2.00	[~3.20]	(N.R.)	
	MEY20-S20-150H	-	~2.60	[~3.80]		MEY32-S32-180H	-	~3.20	[~4.40]	
	MEY20-S20-200	-	2.60	~3.80		MEY32-S32-230	-	3.60	~4.40	
21mm	MEY21-S20	1.40	[~2.60]	(N.R.)	33mm	MEY33-S32	2.00	[~3.20]	(N.R.)	
	MEY21-S20-200	1.40	~2.60	~3.80		MEY33-S32-230	2.00	~3.20	~4.40	
					1.500"	MEY1500-S125	2.20	[~3.40]	[~4.60]	
					40mm	MEY40-S32	2.20	[~3.40]	[~4.60]	
						MEY40-S32-240	2.20	~3.40	~4.60	
					1.984"	MEY2000-S150	2.80	[~4.00]	[~5.20]	
					50mm	MEY50-S42	2.80	[~4.00]	[~5.20]	
						MEY50-S42-250	2.80	~4.00	~5.20	

- (N.R.) means Not Recommended
- The chucking length will be shorter for tools with [] dimension.

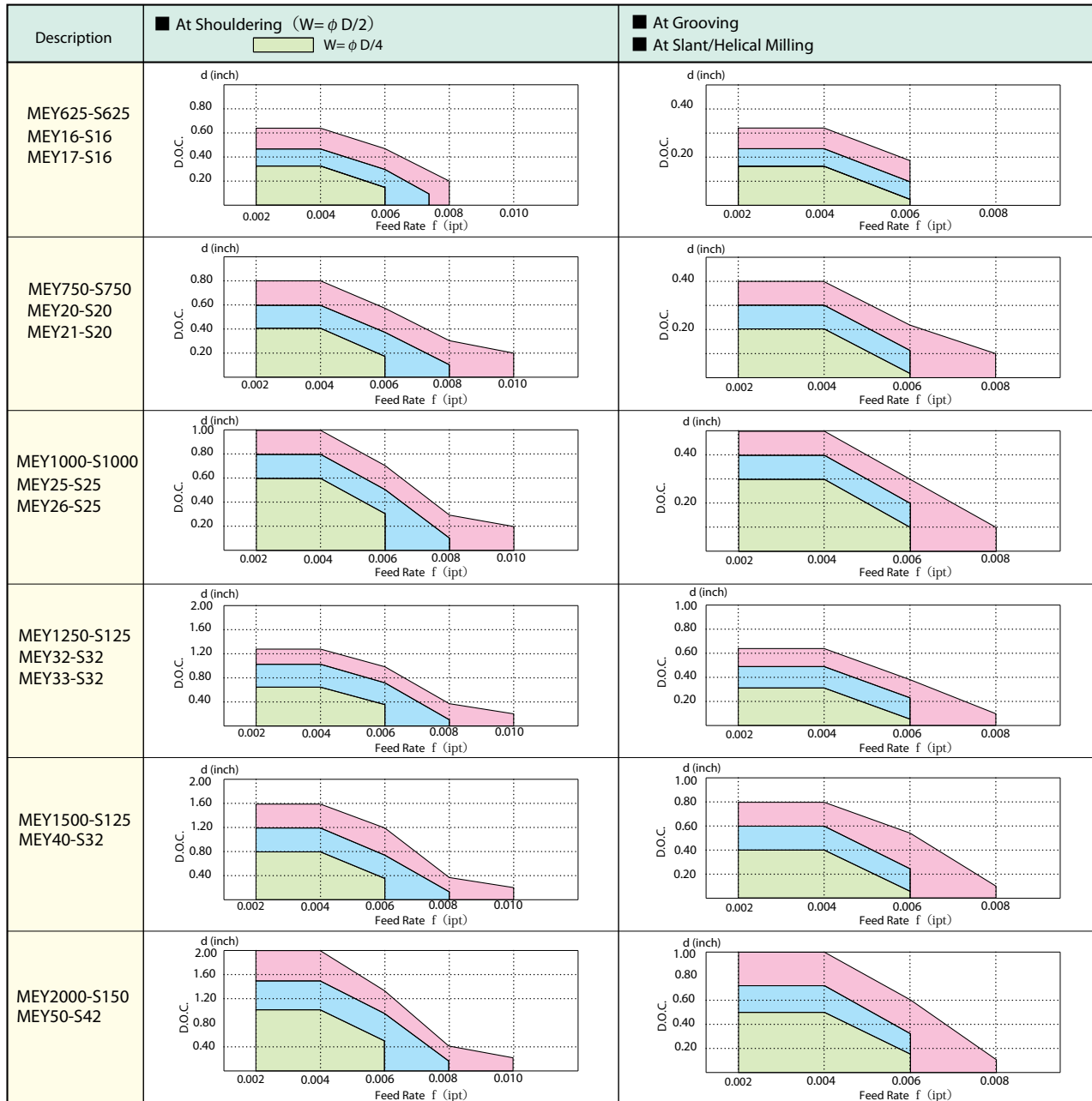

Drilling Depth (For Standard, Long Head, Long Shank: 1050)

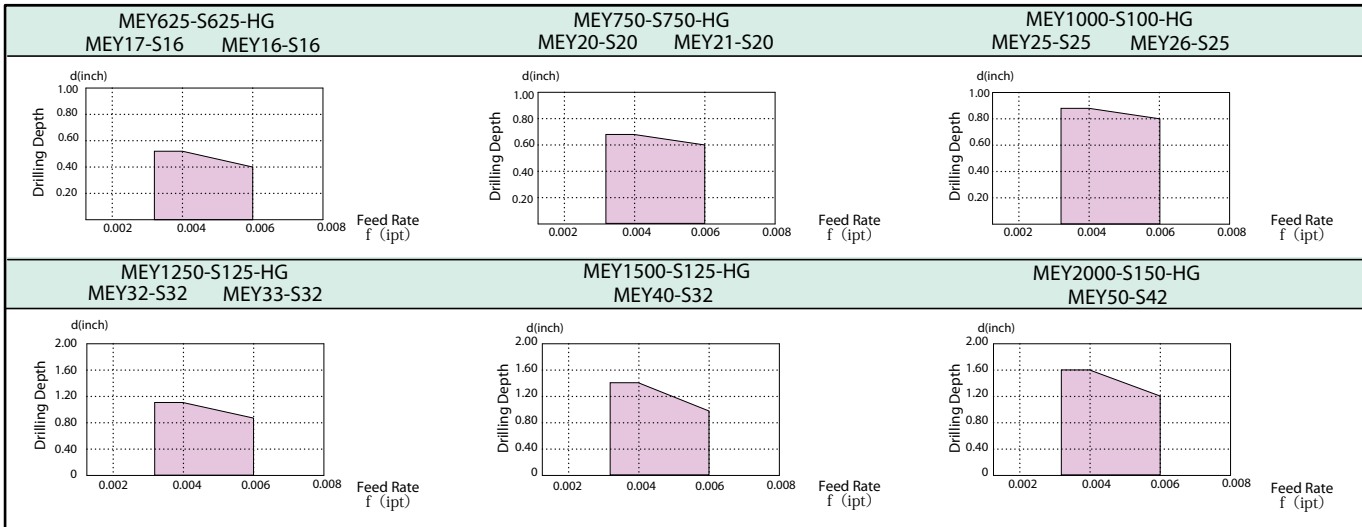

MEY Usage

Drilling

- Drilling conditions shall be calculated as one edge line
- Use compressed air during drilling
- Use step feed method for sticky material
- For stainless steel, wet cutting is recommended

Cutting Dia.	Max. Depth
φ 16mm / φ 0.630"	13mm / 0.52"
φ 17mm / φ 0.669"	13mm / 0.52"
φ 20mm / φ 0.787"	17mm / 0.68"
φ 21mm / φ 0.827"	17mm / 0.68"
φ 25mm / φ 0.984"	22mm / 0.88"
φ 26mm / φ 1.024"	22mm / 0.88"
φ 32mm / φ 1.260"	29mm / 1.16"
φ 33mm / φ 1.299"	29mm / 1.16"

Shouldering

Description	ΦD	Φd
MEY625-S625-HG	0.630"	0.625"
MEY750-S750-HG	0.787"	0.750"
MEY1500-S125-HG	1.500"	1.250"
MEY2000-S150-HG	1.984"	1.500"
MEY17-16	0.669"	0.630"
MEY21-S20	0.827"	0.787"
MEY26-S25	1.024"	0.984"
MEY33-S32	1.299"	1.260"
MEY17-S16-190	0.669"	0.630"
MEY21-S20-200	0.827"	0.787"
MEY26-S25-220	1.024"	0.984"
MEY33-S32-230	1.299"	1.260"

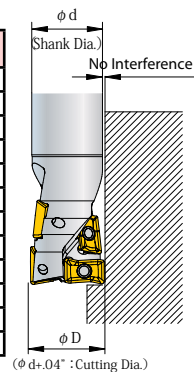

- Tools with larger cutting diameter than shank diameter are available
- High wall shouldering is available

Slant Milling • Helical Milling

- Ramping angle shall be Under 8°
- Plunge depth per revolution at Helical Milling shall be Under 1/2 D
- Use compressed air during machining

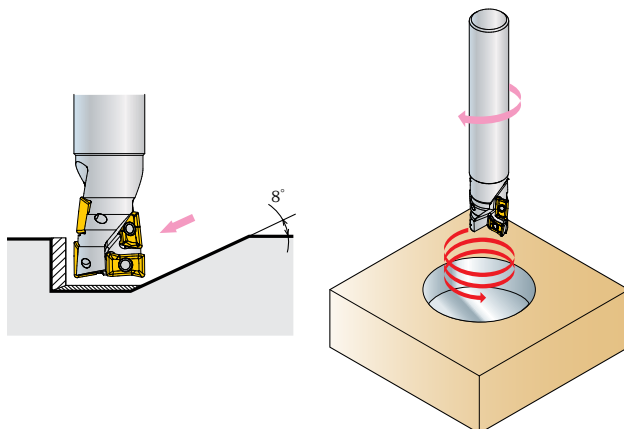

How to Find Factors at Helical Milling

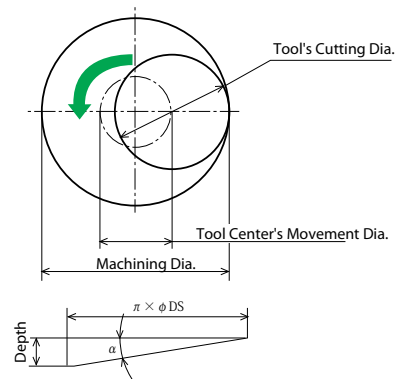

How to Find "φDS"

$$\phi DS = \phi DL - \phi D$$

How to Find "h"

$$h = \pi \times \phi DS \times \tan \alpha$$

(α shall be Under 8°)

MEY Case Studies

1050	
<ul style="list-style-type: none"> • $V=600$ sfm ($N=2300 \text{ min}^{-1}$) • $dxw=0.236" \times 0.276"$ • $F=33$ ipm ($f=0.007$ ipt) <ul style="list-style-type: none"> • MEY25-S25 • JOMT13T308ER-D (PR830) • GOMT13T308ER-D (PR830) 	<p>$\phi 3.1 \rightarrow \phi 3.7"$</p> <p>0.75"</p>
<ul style="list-style-type: none"> • Ultra Drill Mill could machine even at $f=0.007$ ipt ($F=33$ ipm) comfortably without vibration. <p style="text-align: right; font-size: small;">Evaluation from the user</p>	

1050	
<ul style="list-style-type: none"> • $V=400$ sfm ($N=750 \text{ min}^{-1}$) • $d=0.118"$ • $F=7.1$ ipm $d=0.118"$ • $F=1.6$ ipm <ul style="list-style-type: none"> • MEY50-S42 • JOMT160408ER-D (PR830) • GOMT160408ER-D (PR830) 	<p>Helical Milling Machined Portion</p>
<ul style="list-style-type: none"> • Ultra Drill Mill enhanced the machining efficiency greatly. <p style="text-align: right; font-size: small;">Evaluation from the user</p>	

SCM440H	
<ul style="list-style-type: none"> • $V=400$ sfm ($N=2000 \text{ min}^{-1}$) • $d=0.197" \times 3$ passes • $F=23.6$ ipm ($f=0.006$ ipt) <ul style="list-style-type: none"> • MEY20-S20 • JOMT100308ER-D (PR830) • GOMT100308ER-D (PR830) 	<p>$\phi 12.4"$</p> <p>0.60° (0.20° × 3) (0.24")</p> <p>0.60"</p>
<ul style="list-style-type: none"> • Competitor could not machine 20 work pieces, but the Ultra Drill Mill machined more than 20 work pieces with greater stability. <p style="text-align: right; font-size: small;">Evaluation from the user</p>	

Alloy Tool Steel	
<ul style="list-style-type: none"> • $V=350$ sfm ($N=1400 \text{ min}^{-1}$) • $d \times W=0.197" \times 0.394"$ • $F=20.4$ ipm ($f=0.007$ ipt) <ul style="list-style-type: none"> • MEY25-S25 • JOMT13T308ER-D (PR830) • GOMT13T308ER-D (PR830) 	<p>6.5"</p> <p>3.9"</p> <p>0.60"</p>
<ul style="list-style-type: none"> • Even at higher feed rate, consistent machining was available without vibration. As a result, machining efficiency improved. <p style="text-align: right; font-size: small;">Evaluation from the user</p>	